

Patient Monitoring System using GSM and ZigBee Technology

Shweta. Ramteke¹, Mukul Pande², Sandeep Thakre³

¹M. Tech (Communication) Dept. of Electronics & Telecommunication Engg., TGPCET, Nagpur.

²Department of Electronics & Communication Engg TGPCET, Nagpur University Nagpur, India

³Department of Electronics & Communication Engg TGPCET, Nagpur University Nagpur, India

Abstract

Wearable physiological monitoring devices are used to monitor the health status of a patient in Intensive Care Units (ICU). These systems are wired everywhere. A wireless physiological parameter monitoring system is presented in this paper. Literature review carried out in the area of wearable physiological monitoring systems. The proposed system includes sensors for continuous collection and evaluation of physiological parameters. A wireless personal area network has been introduced for reliable transmission of physiological information. The hardware design of this patient monitoring system is based on 8051 microcontroller. Microcontroller acts as the gateway to ZigBee and GSM module. ZigBee wireless communication module has the advantage of lower power consumption which is attractive for portable applications. This system provides safe and accurate monitoring. It also gives the freedom of movement. The proposed system can be used to monitor the physiological condition of a person in out of hospital conditionalso.

Keywords: Physiological monitoring, ZigBee, Microcontroller, GSM

I. Introduction

Biomedical devices benefit from the rapid growth of wireless technology for measuring physiological signals. The use of wireless communications in healthcare systems provides great mobility and increase comfort level of patients [1-4]. The wireless technology for biomedical applications should be suitably selected depending on the data rate and range required for the transmission. With advanced wireless technologies easy access can be made possible and quality healthcare can be provided to people, especially to those residing in the rural areas [5-6]. Shorter Hospital stay and better community care are expected to be the future trend of national health services. Recent advancements in sensor technology wireless communications and information technology in general give opportunities to new models for providing health care and wellness or disease management tools, which enable extended independent living at home and improvement of quality of life for individuals [3].

The biomedical monitoring system discussed in this paper consists of microcontroller, sensors, GSM modem, ZigBee module, power supply and Liquid Crystal Display. The doctor can continuously monitor the condition of the patient and in case of emergency and dangerous situations the system will alert the doctor immediately. The wireless communication link used in this work is a ZigBee based network for communication within the hospital environment.

The system will automatically send SMS in case of emergency situation. This type of communication is done with ZigBee network topology and with the GSM network. Each patient will be given this module and with the help of this module the patient's health condition is continuously monitored. If there is any change in the condition of the physiological parameters, it immediately sends that changed data through ZigBee to the local monitoring system where the main module is connected. The doctor can observe the status of the patient through the computer. The information can be sent as message through GSM network to the care taker or the relative in case of emergency situations.

II. Literature Review

The design and implementation of a telemetry system for measurement and monitoring of bioelectric signals such as EEG, ECG or EMG is discussed in [14]. The proposed system consists of two parts, a portable part and a stationary part. The transmitter uses a pair of 2.8v lithium D cell batteries and can operate for 1.5 months before replacement. The stationary part consists of a commercial radio receiver. The signals can be plotted (using x-y plotter), displayed (using a conventional analogue CRT), or sent to PC system for further processing and interpretation. This system utilizes conventional radio transmitter which consumes very highpower.

AMON is a project financed by the EU FP5 IST program [15]. It consists of on-body sensors integrated in the form of a wrist worn device capable of measuring blood pressure, skin temperature, blood

oxygen saturation and a one lead ECG. It also incorporates a two axis accelerometer for correlating user activity with the measured vital signs. The authors designed a GSM based communication link and also the software for telemedicine centre. To measure the ECG and blood pressure the subject attention is needed. The physiological parameters are not continuously transferred. The inconsistencies of the observed results are also reported by the

Authors. Though it has varying degrees of accuracy on all the measurements, the tests have provided a clear indication of the feasibility of the concepts and validity of the solutions adapted by the project.

An unobtrusive and wearable, multi-parameter ambulatory physiological monitoring system for space and terrestrial application, termed LifeGuard [15] has been developed. The system uses the conventional electrodes to acquire ECG and interfaces a separate non-invasive cuff-based blood pressure monitor and wires from the sensors to the data acquisition hardware are routed around the subject. The system uses the conventional electrodes to acquire ECG and interfaces a separate non-invasive cuff based blood pressure monitor. The different sensors are connected through wires from the crew physiologic observation device (CPOD) and are routed around the subject.

In SmartVest, Pandian et al [16] describe a wearable multi parameter monitoring system which uses an array of on-body sensors connected to a central processing unit for continuously monitoring of physiological monitoring system. The parameters measured are ECG, photoplethysmography (PPG), heart rate, body temperature, blood pressure, and galvanic skin response (GSR).

An instrumented wearable belt for wireless health monitoring is presented in [17]. The instrumented wearable belt device is composed of the electronics and sensors for the monitoring of electrocardiogram (ECG), heart rate (HR) derived from ECG signals by determining the R-R intervals, body temperature, respiratory rate, and three axis movement (acceleration and position) of the subject measured using an accelerometer. The experimental results showed that the cardio- respiratory signals, the heartbeats, the respiratory cycles and the patient movements can be obtained clearly by the device. The instrumented wearable belt makes possible physiological parameter measurements for telemedicine diagnosis, especially for home health care management of aged people.

The above all are some developments in the period of 2000-2013 in the field of sensor based systems for health care application. They were trying to develop successful wireless health monitoring devices. But successful commercial models are yet to reach in medical fields for regular use. Now it is high time to develop wireless monitoring systems for telemedicine applications using latest devices and technology available. It must be made available to local population for their health monitoring to bring the technological developments for the benefit of common man.

In this proposed method of patient monitoring, the ZigBee wireless technology is used for transmission which consumes very low power, so the system can be run months or years without replacement of battery.

III. Methodology

The system consists of microcontroller, sensors, GSM modem, ZigBee module, power supply and Liquid Crystal Display. In case of emergency and dangerous situations the system will alert the doctor immediately. A ZigBee based network is used for the purpose of doctor to patient communication in the hospital environment. For communicating to a distant location SMS facility is implemented.

The emergency situation is indicated to a preset phone number through SMS. This way of communication is actually done with ZigBee network and the GSM network. In a hospital environment each patient is having this module and with the help of this the patient's health condition is monitored. If there is any change in the normal condition of the health parameters, then this module immediately sends that changed parameter to the local central monitoring system in the hospital through ZigBee wireless technology. The same information is transferred as a message or SMS through GSM network to the care taker.

1. Wireless ZigBee technology and GSM for patient monitoring application

Some of the existing and evolving wireless technologies like Satellite communication, mobile communication, WLAN, WPAN, WBAN and WiMAX based systems and their application in the field of telemedicine have been discussed in [8,10].

ZigBee is a specification for a suite of high level communication protocols using small, low-power digital radios or Low-Rate Wireless Personal Area Networks (LR-WPANs), via short- range radio. ZigBee working band is divided into 868MHz, 915MHz and 2.4GHz frequency bands [8-10]. The technology defined by the ZigBee specification is intended to be simpler and less expensive than other WPANs, such as Bluetooth. ZigBee is targeted at radio-frequency (RF) applications that require a low data rate, long battery life, and secure networking. ZigBee is a low-cost, low-power, wireless mesh networking standard. The low cost allows the technology to be widely deployed in wireless control and monitoring applications. The low power-usage allows longer life with smaller batteries. The mesh networking provides high reliability and more extensive range for ZigBee based systems [10,11].

GSM (Global System for Mobile Communications: originally from *Group Special Mobile*) is the world's most popular standard for mobile telephony systems. The GSM Association estimates that 80% of the global mobile market uses the standard. GSM is used by over 1.5 billion people across more than 212 countries and territories. This ubiquity means that subscribers can use their phones throughout the world, enabled by international roaming arrangements between mobile network operators. GSM differs from its predecessor technologies in that both signaling and speech channels are digital, and thus GSM is considered a *second generation* (2G) mobile phone system. This also facilitates the wide-spread implementation of data communication applications into the system.

2. Design of physiological parameter monitoring system

The design and implementation of the monitoring system is based on embedded system. Embedded system is a fast growing technology in various fields like industrial automation, home appliances, automobiles, aeronautics etc.

A. System Architecture at the patient end

The system architecture at the patient end is shown in Figure 1.

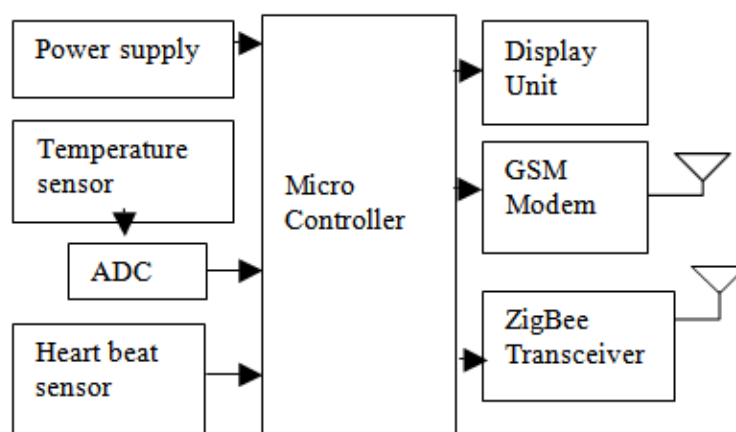

Fig.1 The system architecture at the patient end

Several temperature sensing techniques are currently in widespread use. The most common methods are Resistance Temperature Detectors (RTDs), thermocouples, thermistors, and sensor ICs. The right one for specific application depends on the required temperature range, linearity, accuracy, cost, features, and ease of designing the supporting circuitry [12,13].

In this work IC LM35 sensor is used as temperature sensor. The LM35 series are precision integrated-circuit temperature sensors, whose output voltage is linearly proportional to the Celsius (Centigrade) temperature. The analog information is converted to digital form with the help of ADC. Heart beat sensor is designed to give digital output of heart beat when a finger is placed on it. This digital output can be connected to microcontroller directly to measure the Beats per Minute (BPM) rate.

Heart beat is sensed by using a high intensity type LED and LDR. The finger is placed between the LED and LDR. The skin is illuminated with visible (red) using transmitted or reflected light for detection. This circuit made from an infrared phototransistor and infrared LED. The skin is used as a reflective surface for infrared light. The density of blood in the skin will affect on the IR reflectivity. The pumping action of heart causes the blood density rises and falls. So that we can calculate the heart rate based on the rise and fall of intensity of infrared that reflected by skin. It works on the principle of light modulation by blood flow through finger at each pulse.

If there is any change in the pulses then it is noticed as the change in the heart's normal rhythm. The controller will get an interrupt at this time, which indicates the malfunction of the heart. Then it sends the pulse count with the patient's ID to the doctor in the hospital and at the same time it sends SMS to a preset number stored in the microcontroller.

B. The system architecture at the doctorend

The system architecture at the doctor end is shown in Figure 2.

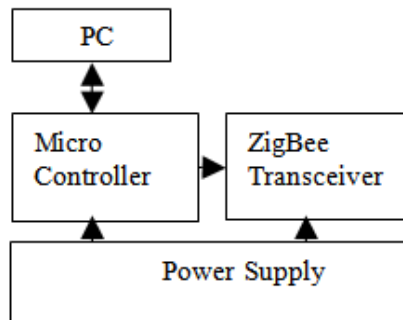

Fig.2 The system architecture at the doctor end

Embedded technology is implemented to perform a specified task and the programming is done using assembly language programming or embeddedC.

The AT89C51 microcontroller is used at the patient end as well as at the doctor end. This is a low-power, high-performance CMOS 8-bit microcomputer. It has 8Kbytes of Flash programmable and erasable read only memory (PEROM). The on-chip Flash allows the program memory to be reprogrammed in-system or by a conventional non-volatile memory programmer. By combining a versatile 8-bit CPU with Flash on a monolithic chip, the Philips AT89C51 is a powerful microcomputer, which provides a highly flexible and cost-effective solution to many embedded control applications.

C. Data Flow Diagram

The data flow diagram is shown in Figure 3.

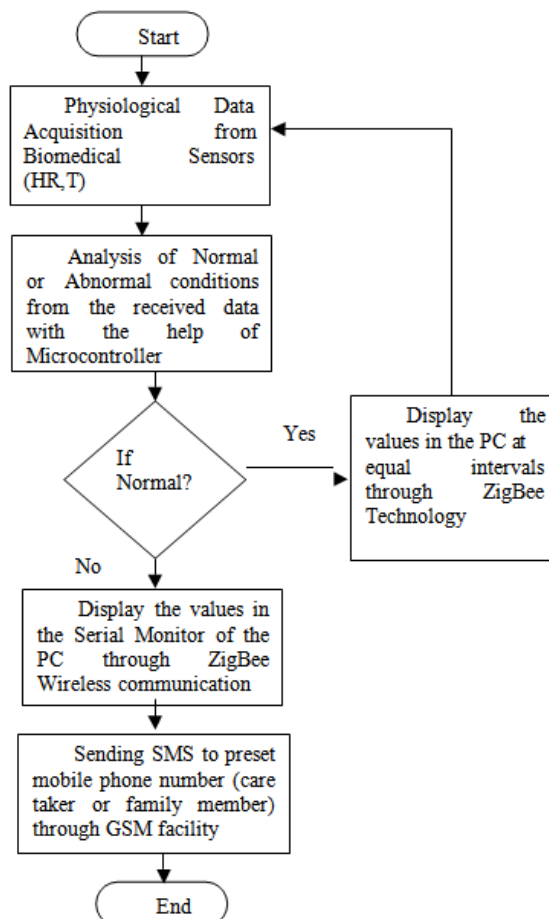

Fig. 3. Data flow diagram

IV. Conclusion

This paper stresses the design of patient monitoring system based on ZigBee and GSM. The biomedical telemetry system consists of temperature sensor, heart beat sensor, pressure sensor, A/D converter, signal conditioning circuit, microcontroller, data cable, mobile phone, LCD display. This is a convenient method to monitor the patient's health condition. The temperature, heart beat and blood pressure are all sensed by using the appropriate sensors which are placed near the patient's body that is under investigation. The sensed output is given to A/D converter where the analog signal is converted to digital signal. The digital output is given to microcontroller. The microcontroller delivers the signal for mobile phone ZigBee and GSM networks. ZigBee and GSM networks enable the user to communicate within the hospital networks as well as to a distant place. The monitoring device can be improved by imparting system for measuring more physiological parameters like glucose level monitoring, ECG, Blood Pressure etc.

References

- [1]. S. Park, S. Jayaraman, "Enhancing the quality of life through wearable technology", IEEE Eng. in Biol Mag May-June 22 (3),2003:41-8.
- [2]. P. Bonato, "Wearable Sensors/Systems and Their Impact on Biomedical Engineering" IEEE Eng. in Med. And Biol. Mag. May-June,2003:18-20.
- [3]. I. Korhonen, J. Parkka, and M. Van Gils, "Health monitoring in the home of the future," IEEE Eng. Med. Biol. Mag., vol. 22, pp. 66-73, May2003.
- [4]. S. C. Mukhopadhyay, A. Gaddam and G. S. Gupta, "Wireless Sensors for Home Monitoring - A Review" Recent Patents on Electrical Engineering ,2008, 1,pp.32-39.
- [5]. I.Korhonen,J.Parkka,andM.VanGils,"Healthmonitoringinthehomeofthefuture,"
- [6]. IEEE Eng. Med. Biol. Mag., vol. 22, pp. 66-73, May 2003.
- [7]. W.Stallings, Wireless Communications and Networks, 1st ed., Prentice Hall,2002
- [8]. L. Zhang, Xiaoming Wu, "Recent Progress in Challenges of Wireless Biomedical Sensor Network" in Proc. Of IEEE 3rd International Conference on Bioinformatics and Biomedical Engineering , Beijing,ICBBE,11-13 June 2009,pp.1-4.
- [9]. N. V. Panicker, A. Suresh Kumar "Recent Trends in Wireless Technologies for Healthcare Applications", in Proc. of Int. Conf. on Emerging Trends in Engineering and Technology (ICETET),Munnar, Kerala, India October 4-5,2013.
- [10]. K.Malhi,S.C.Mukhopadhyay, J Schnepper, M.Haefke and H.Ewald, "A ZigBee-based wearable physiological parameters Monitoring System," IEEE Sensors Journal, Vol.12, No.3,pp.423-430, March2012
- [11]. ZigBee Alliance[online]. Available:<http://www.ZigBee.org/>
- [12]. Karapistoli,E., Gragopoulos,I., Tsetsinas,I. and Pavlidou,F.N., "An overview of the IEEE 802.15.4a standard", IEEE Communications Magazine, Vol. 48, No.1, Jan. 2010,pp.47-53.
- [13]. E.Kyriacou, M.S. Pattichis, C.S. Pattichis, A. Panayides, A. Pitsillides, "m-health and e- emergency systems: current status and future directions," IEEE Antennas and propagation magazine, vol 49, no.1, February2007
- [14]. B.Liu, Y. Zhang and Z. Liu "Wearable Monitoring System with Multiple Physiological Parameters," Proc. Of the 5th Int. Workshop on Wearable and Implantable Body Sensor Networks of the IEEE,China June 1-3,2008,pp.268-271
- [15]. A. A. Al-Imari, Kasim A. Rashid, M. AL-Dagstany, "Telemetry Based System for Measurement and Monitoring of Biomedical Signals", AMSE Journal of Signal processing and Pattern Recognition, Vol. 50, Issue 4,2007.
- [16]. C.W. Mundt, K.N.Montgomery, U.E. Udoh, C.N.Barker, G.C. Thonier, A.M. Tellier, "A multi parameter wearable physiological monitoring system for space andterrestrial applications", IEEE Trans. Inf. Tech. Biomed.,vol.9,no.3,pp.382-391,Sep.2005
- [17]. P.S. Pandian, K. Mohanavelu, K.P. Safeer, T.M. Kotresh, D.T. Shakunthala, P. Gopal, V.C. Padaki, "Smart Vest: Wearable multi-parameter remote physiological monitoring system", Medical Eng. & Physics 30,pp. 466-477,2008.
- [18]. E. Sardini, M. Serpelloni "Instrumented Wearable Belt for Wireless Health Monitoring", Proc. EuroSensors XXIV, September 5-8, 2010, Linz, Austria, Procedia Engineering 5, 2010, pp 580-583.